



► **ClearView Flow Meters**
Installation, Operating &
Maintenance Manual

Technical Specifications

Measuring Accuracy

±2% of full scale

Repeatability

±1% of full scale

Flow Measuring Range

1-30 GPM (5-110 LPM)

Maximum Operating

Pressure 325 PSIG (22.4 Bar)

Maximum Operating Temperature

ClearView H2O 200°F (93°C) (for water)

ClearView+ 250°F (121°C)

Standard Calibration Fluids

Oil monitors: DTE 25® @110°F (43°C), 0.873 sg

Water monitors: tap water @70°F (21°C), 1.0 sg

Filtration Requirements

74 micron filter or 200 mesh screen minimum

Materials of Construction (Wetted Components)

	ClearView H2O	ClearView +
End Ports	Brass, Ryton®	Brass, Ryton®
Seals	Viton	Viton
Spring	Stainless Steel	Stainless Steel
Body	Polycarbonate	Polysulfone
Indicator	Polysulfone	Polysulfone

Ryton is a registered trademark of the Chevron Phillips Chemical Company LLC. Buna-N is a registered trademark of Chemische Werke Huls.

Mechanical - Size Code

DIM	1/2" Female	3/4" Female	1" Female
A	2-7/16" (62 mm)	2-7/16" (62 mm)	2-7/16" (62 mm)
B	7-5/32" (182 mm)	7-9/16" (192 mm)	7-9/16" (192 mm)
B - Brass	7-5/32" (182 mm)	7-9/16" (192 mm)	7-9/16" (192 mm)
B - Ryton	7-9/16" (192 mm)	7-9/16" (192 mm)	7-9/16" (192 mm)
Port Type	NPTF, BSPP	NPTF, BSPP	NPTF, BSPP
DIM	1/2" Male	3/4" Male	1" Male
B - Brass	7-21/32" (194 mm)	8-1/64" (204 mm)	8-3/16" (208 mm)
Port Type	NPTF, BSPP	NPTF, BSPP	NPTF, BSPP

Measurements may vary meter to meter.

Application Information

The flow meter can be installed directly in the fluid line without flow straighteners or special piping. The meter is used to measure the flow rate of most liquids which do not contain particles greater than 74 micron.

1. The casing is made of either Polycarbonate or Polysulphone materials permitting use with a variety of media.
2. The meter may be mounted in the most convenient location, in any orientation to allow easy access for reading and maintenance.
3. The meter should NOT be mounted near hot pipes or equipment which can cause damage to the pressure vessel.
4. The meter should not be mounted in a manner such that piping misalignment or other system components can exert force or produce a bending movement on the pressure vessel.
5. To retain accuracy and repeatability internal moving parts are closely toleranced and require filtration of at least 74 micron or a 200 mesh screen.

Figure 1:
Mechanical Dimensions

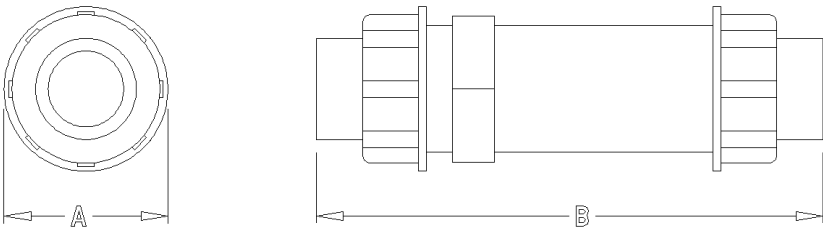

Warning and Precautionary Areas

- 1) The meters are designed to operate in systems that flow in only one direction: the direction of the arrow on the flow scale. Attempting operation in the reverse direction may cause damage to the meter or other system components.
- 2) When installing the meters onto threaded pipe caution should be taken not to over tighten the pipe connections or introduce torque on the main body of the meter. The meter main body may rupture if over-tightened.
- 3) The meter should not be used in systems where the assembled piping is not supported. Externally applied piping forces may cause the meter to rupture or malfunction.
- 4) Operating Pressure: Meters should not be used above the maximum rated operating pressure.

5) Thread seal tape: Caution should be used when using thread seal tape on pipe thread joints. Leave the first thread of pipe thread exposed from the end of pipe when applying tape.

WARNING: Never subject an empty flow meter to an immediate high fluid flow. Always purge air from meters by gradually increasing system fluid flow. A sudden slug of high velocity liquid into an empty flow meter can cause permanent damage to the internals.

Basic Installation Instructions

The meters are mounted in-line and are direct reading. The meters can be mounted in a vertical or horizontal position as long as the fluid is flowing in the direction of the arrow on the flow scale. No straight pipe is required before or after the meter. When installing a meter, apply "Thread Seal Tape" on pipe threads, DO NOT apply pipe dope or Thread seal paste. If tape is used, be sure to leave the first thread of pipe thread on end of pipe exposed. Position filter in front of meter and in a location that allows easy access for routine maintenance. Refer to "Warnings and Precautionary Areas" for additional information.

*Do not apply pipe dope or thread seal paste due to incompatibility with polycarbonate.

INSTALLATIONS DO'S AND DON'TS

To obtain satisfactory operation from the flow meter, the following points should be considered:

DO:

- Place throttling valves at the outlet of the meter
- Use pipe tape on the connections
- Install solenoid valves at meter outlet (as far downstream as possible)
- Mount in any orientation: vertical, horizontal or upside down

DO NOT:

- Use in systems where reverse flow is possible
- Use pipe dope or thread seal paste on the connections
- Place meter in non-aligned piping
- Over-flow the meter beyond maximum reading
- Operate at pressures and temperatures greater than specified

Operation

Operating Principles

Lake has developed a line of unique flow meters which combine the simplicity of a sharp-edged orifice disk and a variable area flow meter. See Figure 2 “Flow Meter Cross Section” below.

The meters are tubular, with all internal wetted parts sealed within the body casing (5). Running through the center of the body casing is a tapered center shaft which is centered in the bore. Encircling the shaft is a sharp edged, floating flow indicator (6). The flow indicator is held in the “no flow” position by the biased return spring (4). As the flow moves through the meter it creates a pressure differential across the floating orifice disk, forcing the disk against the return spring. As flow increases, the pressure differential across the flow indicator increases, forcing the indicator to move along the tapered center shaft. As flow decreases, the biased return spring forces the indicator down the tapered center shaft, returning to the “no flow” position.

Figure 2. Flow Meter Cross Section

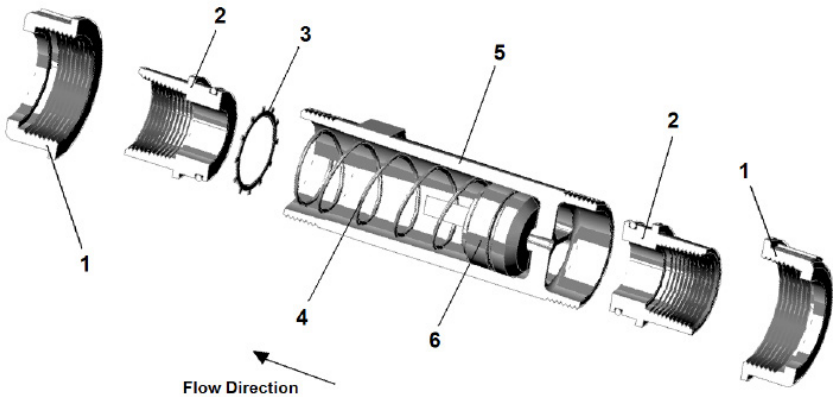

Reading the Meter

Notice the black reference line which runs 360° around the flow indicator. This reference line moves behind the scale in direct relation to the movement of the flow indicator. When fluid is flowing, the flow rate through the meter is read by lining up the black reference line with the closest rate line on the flow scale.

Specific Gravity or Density Effect

Standard meters are calibrated for either WATER with a specific gravity of 1.0 or OIL with a specific gravity of .873. The floating disk meter is affected by fluid density as are most other similar type meters. Lake's meters have less of this effect because of the sharpness of the floating orifice disks being used. The indicated flow reading will read high for heavier fluids and low for lighter fluids. A corrective factor can be applied to the standard scale or a special scale can be added at a slight additional costs. When measuring fluids with other specific gravities, the basic equations below can be used to develop corrected readings.

For water meters use: $\sqrt{1.0/\text{specific gravity}} \times \text{scale reading}$

For oil meters use: $\sqrt{.873/\text{specific gravity}} \times \text{scale reading}$

Troubleshooting & Maintenance

TROUBLESHOOTING CHART	
Malfunction: Magnet follower sticks in mid-scale and will not return to the “no flow” position.	
<p>Possible Cause:</p> <p><i>Horizontal/Vertical Mount</i> Particulate, thread seal tape, rust or other foreign matter is holding the internal parts from returning.</p> <p><i>Horizontal/Vertical Mount</i> A surge or shock in the fluid flow moved the internal magnet faster than the external follower could follow, thus separating the follower from the magnet.</p>	<p>Corrective Action:</p> <p>Disassemble and inspect meter for contamination. Install proper filtration or problem may reoccur.</p>
<p>WARNING: Shut down systems before removing meter from flow line. Remove meter from system. Tip the meter so the arrow on the flow scale points upward. This should return the magnet follower to the “no flow” position. Add some type of surge protection, or problem may reoccur.</p>	
Malfunction: Meter scale reading is off an equal amount at all points and the magnet follower still moves freely.	
<p>Possible Cause:</p> <p>Reading the scale using the top or bottom edge of the magnet follower.</p>	<p>Corrective Action:</p> <p>Be sure to read the scale using the black reference line which runs around the magnet follower.</p>
<p>Possible Cause:</p> <p>Fluid being monitored may not be compatible with standard meter scale.</p>	<p>Corrective Action:</p> <p>Standard meters are calibrated for .873 SP. Gr oil at 110°F (43°C) and water 1.0 SG at 70°F (21°C). Check your fluid data for variance or call the factory for assistance.</p>

TROUBLESHOOTING CHART

Malfunction: Window tube is cracking or crazing.

Possible Cause:

Using incompatible cleaning solution on polycarbonate window tube.

Corrective Action:

Use soap & water or a mild degreaser (Stoddard or Naptha) to clean window tube.

Disassembly

Warning: Shut down system before removing meter from flow line.

1. Use a clean dry cloth to remove all foreign material from exterior of meter, especially around threaded ends.
2. Remove meter from the flow line.
3. Remove outlet retaining nut by turning counter clockwise. Refer to figure 2.
4. Carefully remove retaining clip taking care not to bend or damage it.

IMPORTANT: If inner components does not slide out freely, it may be sign of contamination. Keep it away from metal chips and fillings. They may be hard to remove when reassembling and will cause premature failure.

Cleaning and Inspection

Note: If the inner cartridge is damaged or contaminated beyond repair, the complete meter can be sent to the manufacturer for evaluation. The manufacturer will repair or replace parts as needed.

1. Inspect inner components and body casing for contamination. If the inner components did not slide out freely, it may be a sign of contamination. Locate and eliminate the source of contamination before reconnecting meter to the system or the same problem will reoccur. It may be necessary to install finer filtration or a magnetic filter in the system.
2. Soak inner cartridge assembly in a suitable cleaning solvent. Naptha or Stoddard is recommended.
3. Remove parts from solvent. Use an air hose and/or scrub with a light brush to remove any remaining contaminants. Remove any magnetized particles from transfer magnet.
4. Inspect inner cartridge for scored or worn parts.
5. Remove any contaminants from inside body casing.

6. Clean the window tube with soap and water, or a compatible cleaning solvent.

IMPORTANT: Some solvents may cause damage to the polycarbonate tube, check compatibility of solvent being used.

7. Clean and inspect seal assemblies (O-rings and seals) for nicks or cuts. Replace as needed.

Properly filtered meters will provide years of trouble-free service. If the meter is not properly filtered, it may be damaged and malfunction. Meter damage caused by excessive contamination is not covered under warranty.

Contamination and Filtration

Recommended Filtration

The manufacturer recommends system filtration of at least 74 micron filter or a 200 mesh screen. It has been found that if inadequate filtration has caused meter failure, it will normally fail in the open position. Some systems may require a magnetic filter.

IMPORTANT: Meter damage caused by excessive contamination is not covered under warranty.

Contamination Sources

Fresh Fluid

When fresh fluid is stored in holding tanks, it may be contaminated with scale or metal flakes from inside the tank. To prevent this type of contamination, be sure to filter fresh fluid before adding to the system.

New Machinery Contamination

When building new machines, a certain amount of built-in contamination is unavoidable. Typical built-in contamination consists of dust, dirt, chips, fiber, sand, flushing solutions, moisture, weld splatters and pipe sealants. Flushing the system before operation can reduce contamination, but cannot eliminate it totally. Unless the system is flushed at a high velocity, some contamination will not be dislodged until the system is in operation. System contamination can cause fluid component malfunction.

Environmental Contamination

When performing routine maintenance, the system's fluid is commonly exposed to environmental contamination. Exercise caution during routine maintenance to prevent this type of contamination. Be sure to change breather filter and systems air filter regularly.

Self-Generation Contamination

Self-generated contamination is a product of wear, cavitation, fluid breakdown and corrosion. Systems that are carefully flushed, maintained, and have fresh fluid added, mainly have self-generated contamination. In this case, proper filtration can prevent fluid component malfunction.



414.574.4300 | www.aw-lake.com
2440 W. Corporate Preserve Dr. #600 Oak Creek, WI 53154